

Position(位数)	2P	3P	4P	5P	6P	7P	8P	10P	12P
DIM. A(长度)	6.04[.238]	8.58[.338]	11.12[.438]	13.60[.538]	16.20[.638]	18.74[.738]	21.28[.838]	26.36[1.038]	31.44[1.238]

### 五、包装资料 PACKING

以上产品皆以IC管形式包装。

All DIP Switches are shipped in standard IC tube.

开关位数 NO. OF POS	每管数量 PER TUBE	每盒数量 PER BOX	外箱包装及数量 PER CTN
2	78 PCS	6240 PCS	4 boxes (52.5×28.5×22cm) or 6 boxes (52.5×28.5×32cm)
3	55 PCS	4400 PCS	
4	42 PCS	3360 PCS	
5	34 PCS	2720 PCS	
6	29 PCS	2320 PCS	
7	25 PCS	2000 PCS	
8	22 PCS	1760 PCS	
10	18 PCS	1440 PCS	
12	15 PCS	1200 PCS	

贴片型可采用卷带包装，每卷为900只  
SMT type can be shipped in Tape & Reel Packing.  
the quantity is 900 pcs/reel



Tel: 0086-574-63519686  
Fax: 0086-574-23711368  
Web: <http://www.ccwt.cn>  
E-mail: [ccwt@ccwt.cn](mailto:ccwt@ccwt.cn)  
<http://www.ccwt.cn>

### 一、机械性能

1. 操作力: 800g Max
2. 推钮行程: 0.90mm
3. 使用温度:  $-20^{\circ}\text{C} \sim +70^{\circ}\text{C}$
4. 储存温度:  $-40^{\circ}\text{C} \sim +85^{\circ}\text{C}$

### 二、材料

1. 底座: 工程塑料, 黑色
2. 上盖: 工程塑料, 黑色
3. 推钮: 工程塑料, 白色
4. 端子: 合金铜镀金

### 三、电器性能

1. 电器寿命: 在电压24VDC与电流25mA之下测试, 可来回拨动2000次。
2. 开关不常毁换的额定电流: 100mA, 耐压50VDC。
3. 开关经常切换的额定电流: 25mA, 耐压24VDC。
4. 接触阻抗: 初始值 最大50m $\Omega$ ;  
测试后最大值100m $\Omega$ 。
5. 绝缘阻抗: 最小100M $\Omega$ , 500VDC。
6. 耐压强度: 500VAC/1分钟。
7. 极际电容: 最大5pF。
8. 回路: 单接点单选择。

### 四、焊接和清洗过程

1. 在所有操作过程中, 请确保开关在“off”位置。
2. 波焊: (IC型)推荐焊锡温度在260 $^{\circ}\text{C}$ , 最多5秒钟。
3. 手焊: 使用30瓦烙铁控制温度在320 $^{\circ}\text{C}$ , 焊接时间大约2秒钟。
4. 回流焊: (贴片型)回流炉最高温度为260 $^{\circ}\text{C}$ ; 温度为240 $^{\circ}\text{C}$ 时, 最长不超过20秒。(如图)

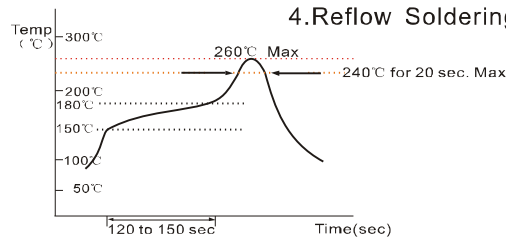

5. 清洗过程: 清洗使用超音波方式, 能给予更好效果; 使用蒸汽清洗时, 温度不可超过51 $^{\circ}\text{C}$ 。

### ●MECHANICAL

- 1.Operation Force: 800g Max
- 2.Stroke: 0.90mm
- 3.Operation Temp:  $-20^{\circ}\text{C} \sim +70^{\circ}\text{C}$
- 4.Storage Temp:  $-40^{\circ}\text{C}$  to  $85^{\circ}\text{C}$

### ●MATERIALS

- 1.BASE: ENGINEERING PLASTICS, Black
- 2.COVER: ENGINEERING PLASTICS, Black
- 3.BUTTON: ENGINEERING PLASTICS, White
- 4.TERMINAL: Alloy Copper, Gold plating

### ●ELECTRICAL

- 1.Electrical Life: 2000 operations cycles per switch
- 2.Non-Switching Rating: 100mA, 50VDC
- 3.Switching rating: 25mA, 24VDC
- 4.Contact resistance: 50 m $\Omega$  max. at initial;  
100m $\Omega$  max. after life test
- 5.Insulation Resistance: 100M $\Omega$ , 500VDC
- 6.Dielectric Strength: 500VAC / 1 minute
- 7.Capacitance: 5pF max
- 8.Circuit: Single pole single throw

### ●SOLDERING AND CLEANING PROCESSES

- 1.Keep all switch contacts in their “OFF” position for all operations
- 2.Wave Slodering: Recommended Solder Temperature at 260 $^{\circ}\text{C}$  max. 5 seconds for IC type.
- 3.Hand Slodering: Use a soldering iron of 30 watts, controlled at 320 $^{\circ}\text{C}$  approximately 2 seconds.while applying solder.
- 4.Reflow Soldering: reflow zone 240 $^{\circ}\text{C}$  for 20 seconds. (for SMT type, see the picture)

- 5.Cleaning Process : Flux clean using force rinse, high agitation or triple bath cleaning method. Freon TF or TE give excellent results. When vapor methods are used do not subject the switch to solvents at temperature above 51 $^{\circ}\text{C}$ .

### 六、产品订购信息HOW TO ORDER

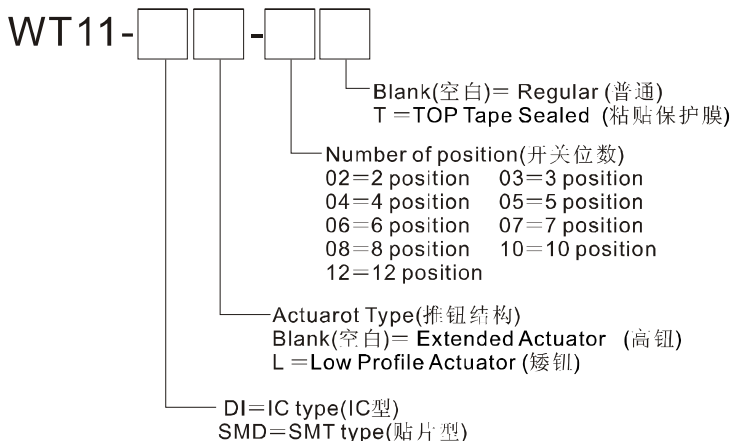

Tel:0086-574-63519686  
Fax:0086-574-23711368  
Web:http://www.ccwt.cn  
E-mail:ccwt@ccwt.cn

<http://www.ccwt.cn>